

STERIL-AIRE®

UVC for HVAC™

SterilWand™ UVC Emitter™

Very High Output
Portable Germicidal
Light Source



The SterilWand™ packages Steril-Aire's multi-patented UVC technology in a versatile, hand-held device designed for decontamination of surfaces infested with mold, bacteria or viruses.

The user slowly passes the device closely over the contaminated surface area, allowing the energy from the high output UVC Emitter™ to decontaminate surfaces. An aluminum safety shield prevents direct exposure to UVC energy, while also adding reflectance that increases the light's effectiveness.

The SterilWand may be used in any type of residential, commercial, industrial or institutional building to provide a fast-acting, portable method of decontaminating tabletops, walls and other surfaces.

In addition to the portable SterilWand, Steril-Aire offers a complete line of installed UVC devices to decontaminate air conditioning coils, ductwork and other HVAC components.

Applications

SterilWand applications include laboratories, hospitals, food and beverage processing areas, schools, libraries and homes. The device is suitable for a variety of specialized uses, e.g.:

- Residential and commercial mold remediation (as a supplement to other control strategies)
- Food preparation, processing, yeast rooms, etc. to reduce contamination



- DNA laboratories to prevent cross-contamination
- Surface decontamination in hospitals
- Libraries, to eradicate mold on book surfaces

Benefits

- Kills or inactivates surface microorganisms that contribute to poor IAQ and/or the spread of infectious disease, including: mold and mold spores, bacteria (including *TB*, *Legionella*, *E. coli*, *Listeria*, *Salmonella* and *whooping cough*); and viruses (including *colds*, *flu* and *measles*).
- Uses patented state-of-the-art solid-state electronic power supply for enhanced reliability and performance.
- Produces no ozone or other secondary contaminants – will not harm building occupants, equipment or furnishings.
- Portable, versatile and easy – just plug in and use. No installation required.
- Proven through independent testing to provide the highest output of any UVC device on the market, for the most effective germicidal control.
- Uses the same tube and power supply as Steril-Aire's Model DE Series UVC Emitter, the industry standard in "UVC for HVAC™".
- Inexpensive to operate – uses approximately the same energy as a 75-watt light bulb.
- Long service life – typically 9000 hours between changeouts.

SterilWand™ Specifications

The UVC Emitter™ and fixture shall be factory assembled and tested. They shall consist of a housing, power source, reflector, safety shield, six-foot power cord, easy-to-grip handle, Emitter sockets and Emitter.

The housing shall be constructed of 304 stainless steel. The reflector shall be constructed of heavy gauge, specular finished aluminum alloy with approximately 85% reflectance at 254 nm wavelength. The safety shield shall be constructed with highly polished, heavy gauge aluminum to enhance the reflectance of the UVC energy. The six-foot power cord shall be UV-resistant. All components shall be in one integral assembly to maximize serviceability.

The power source shall be a Class P, electronic, rapid start type with a power factor greater than 0.95 and a power conversion of greater than 75%. The power supply design shall include RF and EMI suppression. The power supply shall be designed to maximize photon production, irradiance and reliability in cold or moving airstreams of 35-170° F, 100% RH and up to 2000 fpm velocity. The fixture shall be available in 115 Vac, 50/60 Hertz, single phase.

The Emitter sockets are medium bi-pin, double click safety, twist lock type. They shall be constructed of UVC-resistant polycarbonate.

The Emitter tube shall be a very high output, hot cathode, T5 diameter, medium bi-pin type that produces broadband UVC of 250-260 nm. Each tube shall produce the specified output at up to 2000 fpm velocity and air temperatures of 35-170° F. It shall produce no ozone or other secondary contaminants.

Independent testing: Unit shall be tested by an independent test laboratory in accordance with the general provisions of IES Lighting Handbook, 1981 Applications Volume, and shall be verified through independent testing to provide output per inch of glass of not less than 10 μW/cm² at 1 meter in a 400 fpm airstream of 45° F.

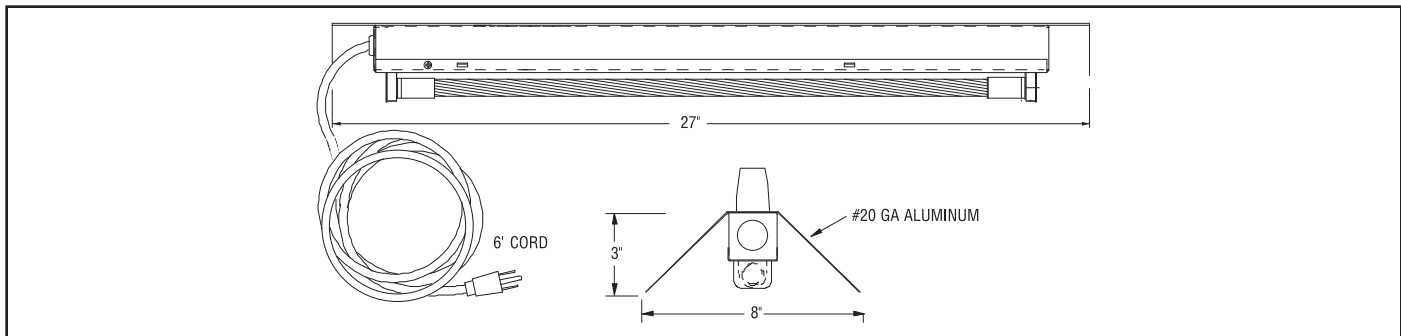

This product may be covered by one or more of the following patents, others pending: 5,334,347/ 5,866,076/ 5,817,276/ 6,372,186/ 6,313,470/ 6,245,293/ 6,267,924/ 6,280,686/ 6,423,882

Ordering Information

Model No.	Part No.	Description	Length	Electrical	Weight
SterilWand	19000200	Double-Ended Fixture	24"	115 V	5 lb.
SterilWand	19000220	Double-Ended Fixture w/ Sleeved Emitter	24"	115 V	5 lb.
GTD 22 VO	20000200	Replacement Emitter SterilWand	22"	N/A	0.15 lb.
GTD 22 VO	20000201	Sleeved Replacement Emitter SterilWand	22"	N/A	0.15 lb.



Steril-Aire, Inc.

Corporate Office:

2840 N. Lima Street
 Burbank, California 91504
 Telephone: 800-2STERIL or 818-565-1128
 Fax: 818-565-1129
 Website: www.steril-aire.com
 Email: sales@steril-aire.com



Registered to ISO 9001:2000
 File No. A13253

Represented By: